

PRODUCT DATA SHEET

Part number 619402

EAN 4015609165827

Manufacturer WALTHER-WERKE

WEEE-Reg.-Number: DE 22131895

Product description

Waterproof panel appliance inlet angled 16A 4P
 2h with screwed flange housing 66x80mm



Similar image





Detailed product description

WALTHER Panel appliance inlet 16A 4P 50-500V 300-500Hz 2h IP67
 angled
 made from PA6 material
 with screwed flange housing
 flange center 66x80mm
 fixing center 40x68mm

Ordering Information

Order unit	Piece
Customs number	85366990
Net weight	0,206 kg
Packing quantity (VPE)	10
Length of the packaging	
Width of the packaging	
Depth of the packaging	
Gross weight(VPE)	2,06 kg

Certificates

VDE certification	123018	
UL certification	No. E83342	
UL certification	No. E188992	
EAC certification	BY112.02.01.020 06091	

Classification system

Classification system	ETIM_6.0
ETIM Class	EC001319

Technical product data

IEC-amperage	16 A
Amperage acc. UL/CSA (for UL-version)	20 A
Number of poles	4
Voltage acc. EN 60309-2	50-500 V (>300-500 Hz) green
Clock hour position	2 h
Identification colour	Green
RAL-number	6025
Degree of protection (IP)	IP67
Connection system	Screwed terminal
Connection type	Built-up device plug
Angle of plug	Angled
Material	Plastic

Dimension sheet

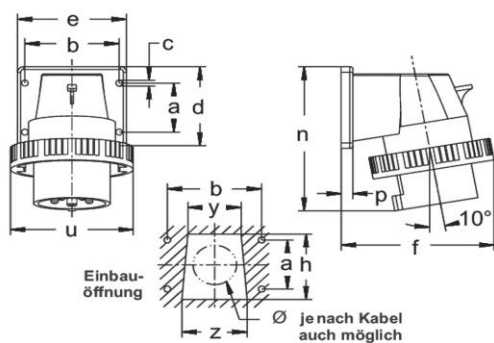

Amp.	16			32			63		
Pole	3	4	5	3	4	5	3	4	5
a	30	40	40	45	45	45	90	90	90
b	55	68	68	78	78	78	90	90	90
c	5,5	5,5	5,5	5,5	5,5	5,5	6,2	6,2	6,2
d	52	66	66	75	75	75	114	114	114
e	65	80	80	90	90	90	114	114	114
f	81	99	103	111	111	117	129	129	129
h	38	52	52	60	60	60	70	70	70
n	98	111	113	131	131	131	184	184	184
p	9,5	9,5	9,5	9,5	9,5	9,5	6	6	6
u	72	81	88	96	96	103	110	110	110
y	30	38	38	44	44	44	56	56	56
z	36	46	46	54	54	54	65	65	65